



RACK PLANNING

DESIGN & BUYER'S GUIDE



Rack Design

A Guide to Selecting the Right Rack Type

Whether planning for a new system installation or a rack replacement, warehouse operators are often confronted with an overwhelming number of choices.

Matching business needs with the appropriate rack system is critical and entails asking the right questions, as well as planning for the flexibility to adapt as your business grows and evolves.

Ensuring flexibility requires doing business with a supplier who can offer a full-range of rack system designs, structural materials, accessories, and custom engineering you may need.

Before you begin the design process with your rack supplier, it will help to identify needs and gather some critical data.

The following information is a guide and general checklist of important considerations that will play a role in the development of your rack system. This guide is meant as an overview only, as each facility and jurisdiction have their own unique requirements, and each facility must comply with local building codes.

Table of Contents

Rack Safety: Determining Your Requirements	3
Rack Design: Selecting the Optimal System	6
Types of Rack	7
Data Collection	10
Rack Material: Is All Steel the Same?	11
Rack Design: Quality in the Details	12
Rack Design: Six-Step Pallet Rack Design	13
Frequently Asked Questions	15
Rack Supplier Checklist	16
Products Built to Last	17



RACK SAFETY



Determining Your Requirements

Product and Turnover

The type and design of your rack will, to a great degree, be determined by your product and stock rotation requirements. How many different product SKUs will be stored? What type, size, and number of pallets will be used? How often will pallets be accessed? Do you require FIFO (first in, first out) or LIFO (last in, first out)? Will processing / picking operations require the integration of automation into your system?

Building Constraints

In addition to the floor space of your facility, take into account all features of your existing structure - ceiling height, sprinkler systems, columns, floor drains.

- > Building column size and spacing
- > Obstructions- HVAC, rat runs
- > Fire code limits
- > Local building code

Be sure to account for sloping floors within your facility, as you will be required to ensure that your rack uprights are plumb. Check your slab-on-grade capacity. Can your existing concrete floors accommodate the weight of the system you plan to install? Do they require any special rack anchoring considerations?

You will also need to map out your means-of-egress for both personnel and forklift access to ensure that maximum distances to egress are within code, especially for raised work areas.

Production Zones and Work Flow Areas

Consider the space needed for your production work to occur safely. For a stock and ship operations, adequate space is required for packing, shipping, and receiving areas.

Temperature

Temperature and humidity are factors in determining rack design, as materials perform differently in a cooler or freezer environment. Load Capacity Your required load capacity can be calculated by multiplying your maximum pallet weight (including the pallet) by the number of pallets stored on one pair of rack beams. For example, if you place two pallet loads of 2000 lbs each side-by-side on the rack, you need a rack beam with a capacity of at least 4000 lbs per pair to support the load safely. Rack manufacturers provide charts to help select the appropriate beam. This capacity rating is based on a set beam spacing. Any adjustments made to the configuration of a rack, such as a change in beam placement or height, must be reviewed by a racking specialist before it is put back to use.

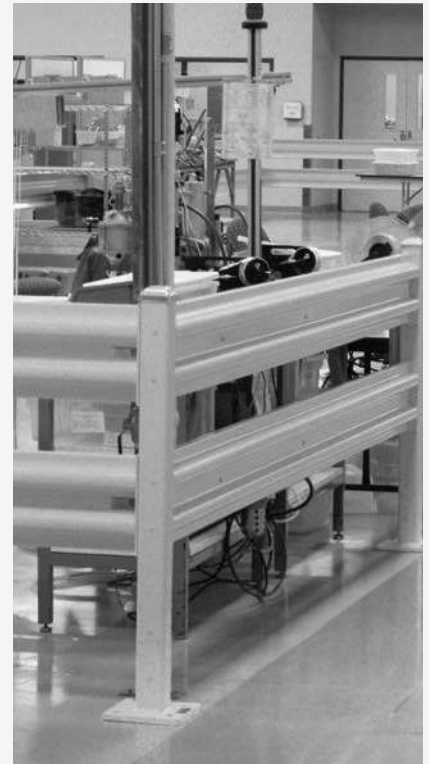

Code Compliance & Permitting

Rack systems may be installed only after all applicable building codes have been satisfied and a building permit has been issued for a particular system design, geographic location, and a particular user's application. In most jurisdictions, the applicable building code is the legislatively- adopted edition of the International Building Code (IBC) as developed, updated, and promulgated by the International Codes Council (ICC). Some localities enforce a variant of the IBC. The owner must work with the rack equipment provider to determine which code applies and to assure that their system will be designed, manufactured, and installed to satisfy all applicable requirements.

In addition to local building codes, some industries have specific code compliance requirements, including rack capacity plaques.

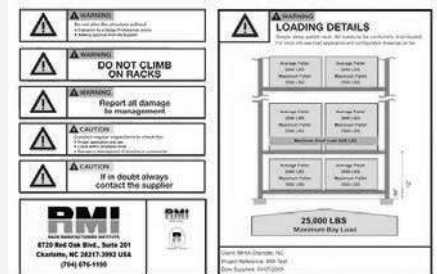

Environmental Forces

Seismic design categories, along with wind and snow loads must be taken into consideration for rack-supported structures.

For free standing rack structures, adequate seismic separation must be engineered into your rack system.

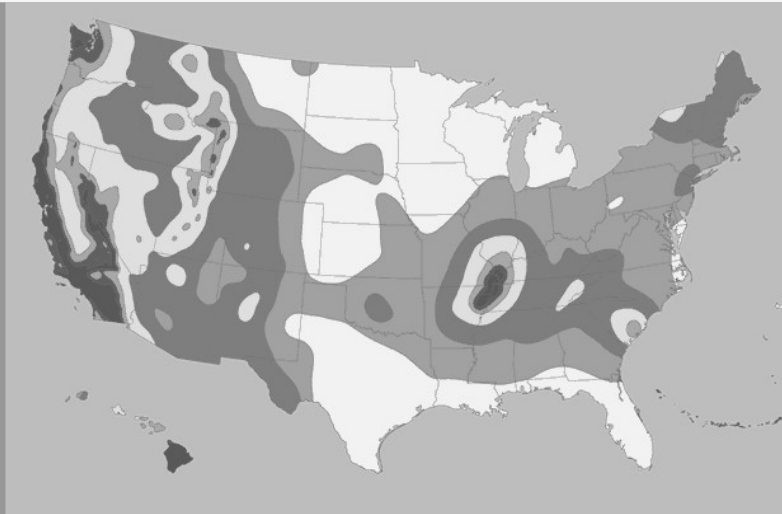

The old “seismic zones” no longer exist. Now there are “seismic design categories”. Even within the same category, exact latitude and longitude of the project affect the seismic forces which must be applied to the rack design calculation.

Example: two locations within the same zip code, second location required 100% more seismic force.



According to OSHA, all goods, materials and equipment at work sites must be stacked, stored, and secured in such a way that they do not flow, move, roll, or collapse.

Storage racks are considered “building-like, non-building structures.” Therefore, according to the International Building Code, and as reflected in the Rack Manufacturer’s Institute (RMI) Standard, racks must be designed to local seismic requirements, just like a building.

Plan for Long-Term Success

An integral part of every rack planning project is to recognize the importance of rack inspection and maintenance.

Developing a partnership with a Rack Manufacturers’ Institute (RMI)-certified rack partner who understands your business goals will help you plan today’s system with tomorrow’s success and evolution in mind.



Rack Design

Selecting the Optimal System

One of the largest space-saving opportunities for many companies lies in optimizing storage depth.

Selecting the right type of rack system begins with not merely identifying how to optimize your space for more storage, but for product movement as well. If you have a large number of SKUs that take up only one pallet position, simple selective rack is probably a good choice, however, warehouses that have a significant number of SKUs regularly filling two to three pallet positions, may want to consider storage systems other than single-deep pallet rack.

Often the most efficient storage and retrieval of product will be a mix of rack types, particularly if you need to accommodate fast-moving goods or seasonal variation.

We will take a look at the various rack types in the following pages.



Pallet Racking Type	Low Investment	High Storage Density	Easy to Adjust & Adapt	Individual Pallet Access	Handling Mixed Articles	FIFO Possible
Standard aisle	√√		√√	√√	√√	√√
Narrow aisle	√	√	√	√√	√√	√√
Drive-in	√	√√				
Pallet shuttle system	√	√√				√√
Pallet flow		√√				√√
Pushback		√			√	



Selective Rack



Double Deep

Types of Rack

Selective Rack

The most popular type of rack is Selective Rack, which allows direct access of each pallet position from the aisle. While selective rack does not make the most complete use of floor space, it may be the ideal solution for many companies.

Selective pallet racking is a popular and effective storage method for nearly 80% of product in warehouses, manufacturing facilities and distribution centers due largely to ease of design and installation.

- > Each storage location accessible
- > Less density
- > Low purchase cost

Double Deep

Double Deep rack systems are designed to increase storage capacity while still maintaining a high degree of selectivity. Pallets are stored two deep on a single-sided unit or four deep on double-sided racks.

- > 50% storage locations easily accessible
- > 100% greater density
- > Slightly higher purchase cost
- > Requires special truck
 - Telescoping Forks
 - Outriggers
 - Have to design rack with wider bays or first beam level not on floor





Drive-in/Drive-through



Pallet Flow (Gravity) Flow

Drive-in or Drive-through

A Drive-In Rack increases density and is often utilized where group pallet selection is more likely than individual pallet selection. With Drive-in Rack, loading and unloading within a bay must be done from the same aisle. A similar system called Drive-Thru Rack permits loading and unloading from both ends of a bay.

- > Two or more deep
- > High density
- > Loads on "rails"
- > Slightly higher purchase cost
- > Truck travels in rack
- > Rack protection from truck damage recommended

Pallet Flow (Gravity Flow)

SK3400® is a Gravity Flow storage system consisting of flow rails are set at an incline in the rack structure, allowing loads placed on one end of the rack to move down to the unloading end. Pallet flow rack is ideal for FIFO (first in, first out) inventory management.

- > 2 or more deep
- > High density
- > Loads on wheeled "rails" with brakes
- > FIFO
- > Highest purchase cost
- > Lower handling cost



Pushback

Pushback

Pushback Rack can be used to store pallets from two to six positions deep, without sacrificing additional space to aisles. Pallets are loaded into the same side of the system from which they are picked without the use of a special lift truck. Each vertical level of storage can be used to store a different SKU. One drawback is that FIFO (first-in, first-out) storage is not accommodated.

- > 2 to 6 deep
- > Loads placed on telescoping carts
- > Each level independent
- > Higher purchase cost



Cantilever

Cantilever

Cantilever Rack is primarily utilized to store bulk items such as building materials (lumber, pipe, drywall, etc.) and furniture. It is commonly found in home centers and furniture warehouses. Cantilever Rack is easily identified by the arms protruding from the face of the columns.

- > Cantilever rack can accommodate non-palletized loads
- > There are no front columns to obstruct access
- > Single- or double-sided
- > Available in multiple capacities

Data Collection

Your product pallets and material handling equipment also help to determine features of your rack.

Fork Truck Type

Today's rack types and technologies allow full optimization of your storage area, however, taller rack systems and narrower aisles may require special lift equipment.

Every forklift needs room to maneuver. Depending on the type of forklift, the aisle will be wider or narrower.

Tall or deep rack systems will require lifts with extended forks or greater reach.

Pallets

There are a great number of pallets types on the market. Each rack system needs to be designed with the pallet in mind.

In addition to the dimensions of the pallet itself, the beam spacing of the rack will need to accommodate the need for both pallet height and vertical lift space.

Pay particular attention to how the pallet will rest on your rack beams, what will keep a misplaced pallet from falling. There are a wide variety of solutions, including various pallet supports and load stops.

For some types of rack, the condition of your pallets will also be a factor. A broken pallet can jam a flow rack or cause damage and injury in a drive-in system, where the pallet supports the load.

It is also essential to include the weight of the pallets within your load capacity requirements.



ALERT:

Pallet Dimensioning differs in rack industry versus pallet industry! Don't forget weight of pallet in beam capacity.

PALLET STYLES

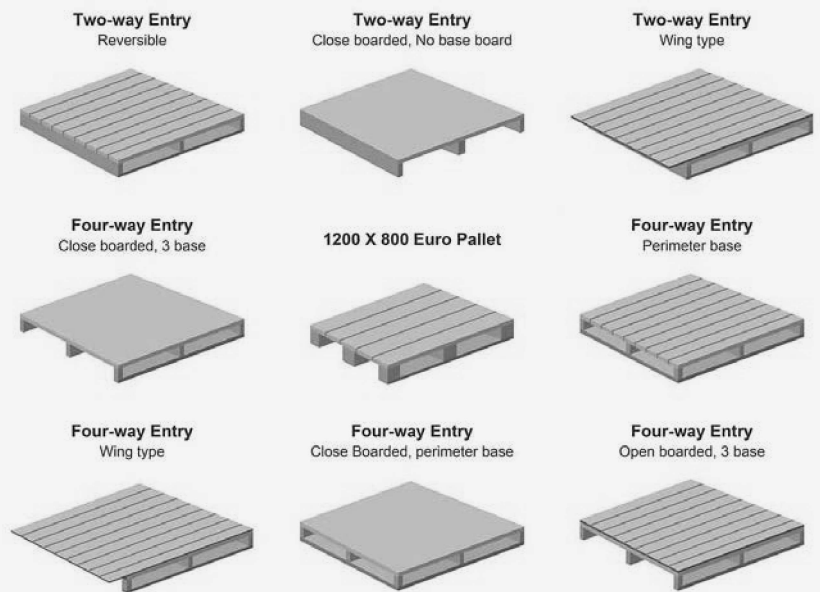



Roll-Formed Steel



Structural Channel Steel

Rack Material IS ALL STEEL THE SAME?

Along with the rack type, the steel type and fabrication are also critical decisions that will affect the strength, durability and safety of your system.

Steel rack material varies greatly from one rack type to the next.

- › The chemical composition of the steel can vary greatly. Steel is an alloy and can be comprised of varying percentages of its component metals, or amount of recycled material, which can affect its strength. Better steel means better quality and safety.
- › Steel made in the U.S. must conform to standards that imported steel does not.
- › How the steel is formed at the mill also has a profound effect on the way it performs. There are two main types of steel used in the fabrication of rack frames – cold-rolled (structural channel) steel and hot (roll-formed) steel.
- › Steel that we refer to as “roll-formed” is made by a process called cold roll forming: sheets of cold steel are bent with rollers to form the shapes for the uprights and beams. Structural steel is made from hot rolled channels of steel.

Rack Design

QUALITY IN THE DETAILS

Engineered for Strength

While roll-form rack is made of a lighter gauge of steel than structural, it can be engineered for strength and impact resistance by using a fully-closed structure.

Third-party engineering tests comparing open-back to closed-back rack have proven that “closed-tube” configuration provides:

- > 250% more frontal impact resistance than a comparable open-back column.
- > 44 times more torsional strength (resistance to twisting)
- > 68% more side impact resistance
- > Rack frames that also use closed tubes for frame braces and step beams provide even greater durability and stability.

Certified Welding

- > Fabrication details can also impact the safety and life expectancy of your system. Note the difference in the connection interface. The use of a “full-fillet” weld will provide far greater durability than “stitch” or “spot” welding.
- > Your rack system is only as strong as its weakest weld. Working with a manufacturer whose welders and processes meet American Welding Society / Canadian Welding Bureau standards can help ensure the durability and longevity of your rack investment.



Cross Section of Frame Column

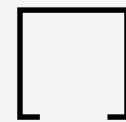

**Open Back
Column**

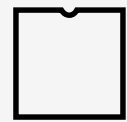

**SK2000[®]
Closed Column**



Rack Design

SIX-STEP PALLET RACK DESIGN

Determining Pallet Rack Configurations

1. Find the depth and width of your pallet.
2. Determine the load depth, load width, load height and weight of your largest load. For the overall height, add the height of the load and the height of the pallet together.

3. To determine front-to-back depth of your uprights, subtract 6" from your pallet depth.

Example: Your pallet is 40" Wide x 48" Long (Depth). Subtract (48" - 6") = 42" Uprights

4. Determine the beam width (assumes 2 pallets per beam): Multiply the load width x 2 and add 12".

Example: Your load width is 42": $2 \times 42" = 84" + 12" = 96"$ beam length. If required, round the length up to the next highest beam length.

5. Check the beam capacity to ensure the specified beams will carry the planned load. Do not exceed beam capacity.

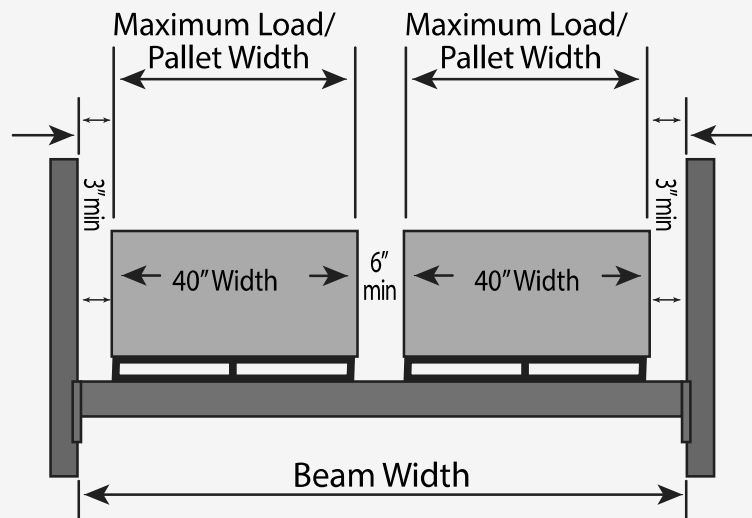
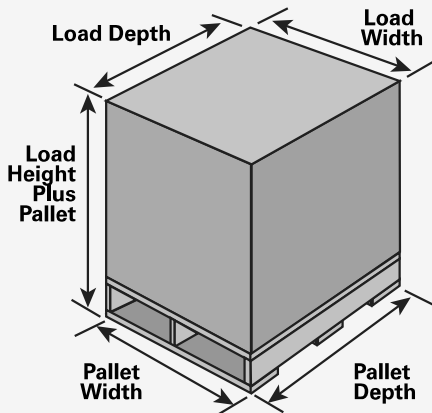

6. Calculate your upright height (for a system using 4" beams):

(A) Multiply the number of pallets high stored minus one pallet x 10".

Example: If storing 4 pallets high: 4 pallets high minus one pallet is 3, then multiply 3 pallets x 10" = 30"

(B) Multiply the number of pallets high stored minus one pallet by the overall load height. Include the pallet height in the overall load height.

Example: If storing 4 pallets high, with an overall load height of 50": 4 pallets high minus one pallet is 3, then multiply 3 pallets x 50" = 150".

(C) Add the two numbers you solved for together (30" + 150" = 180" in this case).

This number is your upright height. See table for standard upright sizes.

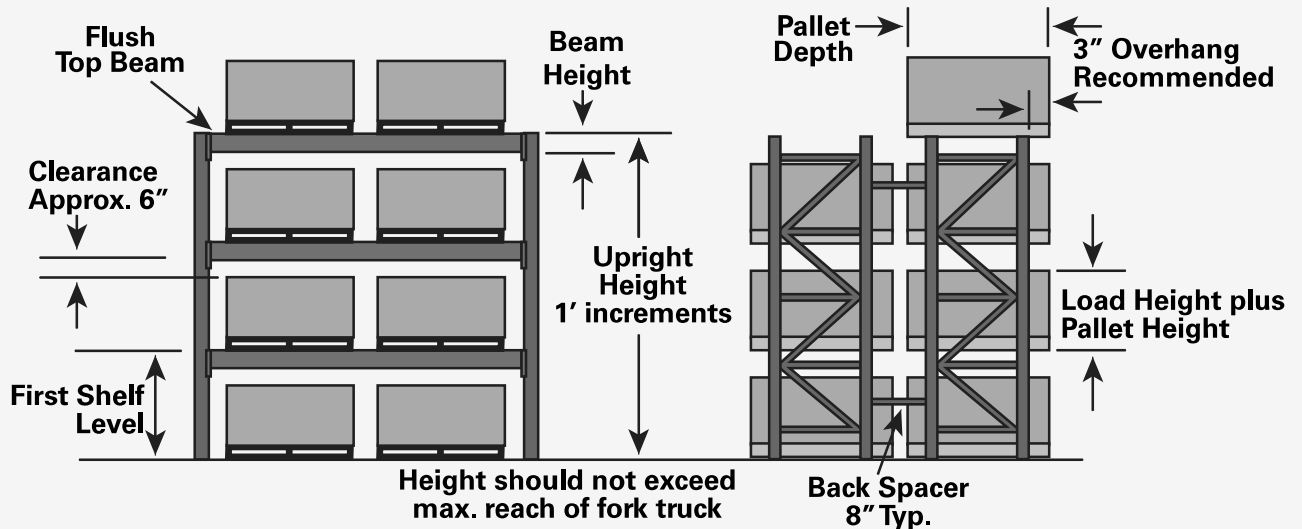

If you have special requirements or questions, please contact your nearest dealer or call Steel King at (800) 826-0203.

Notes on Upright Height:

- > The vertical space between pallets allows for the beam height, and also vertical clearance to lift and remove the pallet.
- > Be certain there is adequate space left between load height of uppermost pallet and sprinkler heads, light fixtures, and other obstructions that may exist overhead.

Frequently Asked Questions

Can rack components from different manufacturers be mixed and connected together in the same installation?

Most rack manufacturers produce unique and proprietary components. Column shapes and hole punching patterns along with the mating beam end connectors are designed to interface specifically with each other. While some different manufacturer's products may seem somewhat compatible, they are not interchangeable. Mixing these products may cause fit and/or function issues and may void the original equipment warranty.

The beam-to-column connection properties are of vital importance in the proper structural analysis of the rack system. It cannot be assumed that products from different manufacturers can be connected together without any adverse effects.**

What about buying used rack?

Installing used rack is not recommended. Used rack may be structurally compromised prior to or during the removal, shipping and/or re-installation process. In addition, the new use of the racking may not be the purpose for which the racking was originally designed. When moving rack, there may be seismic zone differences to consider.**

How would I know if I need a building permit for my rack system?

Rack structural systems, not unlike building structures, are often subject to the building code review and permitting process. The pertinent building code is usually required by a municipality, county, or state. Most building codes which have been adopted and are being enforced include rack structures - e.g., the International Building Code, the NFPA, and the earlier UBC, BOCA, and SBC model codes. Those provisions often include the requirement of a local building permit.

Occasionally, local requirements may differ slightly from the more generally-applied national and international building codes. The user should determine from local authorities which building code is applied and should report that information to the rack manufacturer.**

When purchasing storage rack, be sure to specify in your order that the racks must be designed in accordance with the latest edition of the RMI Specification and Commentary.

****For additional specifications, RMI (Rack Manufacturers Institute, Inc.) has a wealth of resources available on their website www.mhi.org/rmi.**

Rack Supplier Checklist

When it's time to purchase new pallet racking for your warehouse, there are a number of factors you'll want to consider.

Take time to research the features and benefits head-to-head before you make a commitment to buy. We've listed out some of the features that you'll want to consider.

Roll-Form Rack	SK	#2	#3
Footpad with multiple offset anchor holes			
Flush footpad			
Footpad ridge			
Heavy horizontal (1"x2") closed tube			
Two 2" brace to column welds			
4" total weld per horizontal brace			
Closed-tubular upright/column ridge			
55,000 PSI minimum yield steel			
Holes on column face (not corner)			
Boltless 3- or 4-rivet connection			
Interchangeable connection			
Seamlessly welded step beams			
Auto-engaging safety locks			
Replaceable safety locks			

Structural Rack	SK	#2	#3
Heavy duty 7-gauge footpad			
Multiple offset anchor holes			
Heavy horizontal			
Factory welded frame for increased impact resistance			
Structural angle bracing			
50,000 PSI minimum yield steel			
Preliminary seismic calculations done			
Beams welded with precision robotics			
Grade 5 bolts w/ serrated whiz nuts			
Beams welded to heavy 7-gauge wrap-around connector plate			
Replaceable safety locks			

Company Strength	SK	#2	#3
RMI 2012 certified			
AWS certified welders			
4A1 Dun & Bradstreet Financial Rating			
LA & Phoenix City Certified Manufacturer			
Licensed on-staff professional engineer			

Quality of Products	SK	#2	#3
Manufactured in house, not 'jobbed out'			
Delivered by enclosed Tautliner and tarped flatbed			
Protective packaging helps reduce freight damage			
Easy installation, highest tolerances			
Powder coat finish			
13 Standard colors			

Rack Supplier #1 Steel King Industries

Rack Supplier #2 _____

Rack Supplier #3 _____





DESIGNED TO PERFORM PRODUCTS BUILT TO LAST

For over 50 years, Steel King Industries, Inc. has produced high-caliber material handling racking, storage, and safety systems that improve, fortify, and protect company's supply chains nationwide. With unparalleled standards of safety and quality, we manufacture storage solutions ranging from the industry's top containers, work platforms, and rack systems, to highly engineered distribution facility systems that are foundational for an automated supply chain. Steel King's reliability, strength, and support have earned recognition and loyalty as one of the top rack manufacturers in North America, as we proudly contribute vitality, efficiency, and value to supply chains worldwide.

Support for Support

At Steel King, we stake our reputation on supporting people—not just inventory. We're here to help you specify the high-density solutions to meet the needs of your operation, space, and budget.

Scan to learn about
our complete solutions
and why our products
are BUILT TO LAST.



Rack and Systems

The ultimate in design and execution, customized for your space and requirements. Built tough, forklift-friendly, and ready to store any inventory.

- > Pallet Racks
- > Cantilever Racks
- > Drive-In / Drive-Through Racks
- > Flow Rack / Pushback Racks
- > Pick Module Racks
- > Specialty Racks
- > Portable Racks
- > Custom Shipping Racks
- > Support Structures / Work Platforms

Safety Products

Steel King's safety products extend the life of your facility and have been setting industry standards in safety, protecting your people, product, and plant.

- > Guard Rails
- > Safety Gates
- > Pallet Load Stops and Supports
- > Lift-Out Rails
- > Rub Rails

Containers

Steel King manufactures a full line of industrial storage containers for heavy-duty stackable storage, scrap handling, line assembly dispensary, parts distribution, and other uses. We offer essential, industry-standard designs as well as fully-custom containers suited to your storage requirements.

- > Transportable Containers
- > Bulk Containers
- > Collapsible Containers
- > Work in Progress (WIP) Containers
- > Steel Pallets



STEEL KING®
BUILT TO DELIVER

steelking.com

| 800-826-0203



2305-WP-Rack Planning